

DDR3 Registered/ECC DIMM Module

1GB based on 1Gbit component

82FBGA with Pb-Free



Revision 1.0 (May, 2008)
-Initial Release

1.0 Feature

- JEDEC standard $V_{DDQ}=1.5V \pm 0.075V$ Power Supply
- $V_{DDQ} = 1.5V \pm 0.075V$
- Programmable CAS Latency: 6,7,8,9,10,11
- Programmable Additive Latency(Posted CAS) : 0, CL - 2, or CL - 1 clock
- Programmable CAS Write Latency(CWL) = 5(DDR3-800), 6(DDR3-1066), 7(DDR3-1333) and 8(DDR3-1600)
- 400MHz fCK for 800Mb/sec/pin, 533MHz fCK for 1066Mb/sec/pin, 667MHz fCK for 1333Mb/sec/pin, 800MHz fCK for 1600Mb/sec/pin
- 8-bit pre-fetch
- Burst Length: 8 (Interleave without any limit, sequential with starting address “000” only), 4 with tCCD = 4 which does not allow seamless read or write [either On the fly using A12 or MRS]
- Internal(self) calibration : Internal self calibration through ZQ pin (RZQ : 240 ohm \pm 1%)
- Bi-directional Differential Data Strobe
- Asynchronous Reset
- On-Die termination using ODT pin
- 8 independent internal bank
- Average Refresh Period 7.8us at lower than a TCASE 85°C, 3.9us at 85°C < TCASE < 95 °C
- Serial presence detect with EEPROM
- RDIMM Dimension (Nominal) 30.00 mm high, 133.35 mm wide
- Based on JEDEC standard reference Raw Cards Lay out.
- RoHS compliant
- Gold plated contacts

2.0 Ordering Information

Part number	Density	Module Organization	Component composition	Component PKG	Module Rank	Description
W10RA1G8x	1GB	128Mx72	128Mx8*9	FBGA	1	PC3-8500

Note: Last Character x of the Part Number stand for DRAM vendor
S=Samsung; M=Micron; H=Hynix

3.0 Operating Frequencies

	DD3-1066	Unit
CL-tRCD-tRP	7-7-7	tCK
CAS Latency	7	tCK
tCK(min)	1.875	ns
tRCD(min)	13.125	ns
tRP(min)	13.125	ns
tRAS(min)	37.5	ns
tRC(min)	50.625	ns

4.0 Absolute Maximum DC Rating

Symbol	Parameter	Rating	Units
V_{in}, V_{out}	Voltage on any pin relative to V_{SS}	-0.4 ~ 1.975	V
V_{DD}	Voltage on V_{DD} & V_{DDQ} supply relative to V_{SS}	-0.4 ~ 1.975	V
V_{DDQ}	Short circuit current	-0.4 ~ 1.975	V
V_{DDL}	Power dissipation	-0.4 ~ 1.975	V
T_{STG}	Storage Temperature	-55 ~ + 100	°C

5.0 DIMM Pin Configurations (Front side/Back side)

Pin	Front	Pin	Back	Pin	Front	Pin	Back	Pin	Front	Pin	Back	Pin	Front	Pin	Back
1	V _{REFDQ}	121	V _{SS}	31	DQ25	151	V _{SS}	61	A2	181	A1	91	DQ41	211	V _{SS}
2	V _{SS}	122	DQ4	32	V _{SS}	152	DQS12	62	V _{DD}	182	V _{DD}	92	V _{SS}	212	DQS14
3	DQ0	123	DQ5	33	$\overline{\text{DQS3}}$	153	$\overline{\text{DQS12}}$	63	NC	183	V _{DD}	93	$\overline{\text{DQS5}}$	213	$\overline{\text{DQS14}}$
4	DQ1	124	V _{SS}	34	DQS3	154	V _{SS}	64	NC	184	CK0	94	DQS5	214	V _{SS}
5	V _{SS}	125	DQS9	35	V _{SS}	155	DQ30	KEY				95	V _{SS}	215	DQ46
6	$\overline{\text{DQS0}}$	126	$\overline{\text{DQS9}}$	36	DQ26	156	DQ31	65	V _{DD}	185	$\overline{\text{CK0}}$	DQ47	DQ42	216	DQ47
7	DQS0	127	V _{SS}	37	DQ27	157	V _{SS}	66	V _{DD}	186	V _{DD}	97	DQ43	217	V _{SS}
8	V _{SS}	128	DQ6	38	V _{SS}	158	CB4	67	V _{REFCA}	187	$\overline{\text{EVENT}}$	98	V _{SS}	218	DQ52
9	DQ2	129	DQ7	39	CB0	159	CB5	68	NC/Par_in	188	A0	99	DQ48	219	DQ53
10	DQ3	130	V _{SS}	40	CB1	160	V _{SS}	69	V _{DD}	189	V _{DD}	100	DQ49	220	V _{SS}
11	V _{SS}	131	DQ12	41	V _{SS}	161	DQS17	70	A10/AP	190	BA1	101	V _{SS}	221	DQS15
12	DQ8	132	DQ13	42	$\overline{\text{DQS8}}$	162	$\overline{\text{DQS17}}$	71	BA0	191	V _{DD}	102	$\overline{\text{DQS6}}$	222	$\overline{\text{DQS15}}$
13	DQ9	133	V _{SS}	43	DQS8	163	V _{SS}	72	V _{DD}	192	$\overline{\text{RAS}}$	103	DQS6	223	V _{SS}
14	V _{SS}	134	DQS10	44	V _{SS}	164	CB6	73	$\overline{\text{WE}}$	193	$\overline{\text{S0}}$	104	V _{SS}	224	DQ54
15	$\overline{\text{DQS1}}$	135	$\overline{\text{DQS10}}$	45	CB2	165	CB7	74	$\overline{\text{CAS}}$	194	V _{DD}	105	DQ50	225	DQ55
16	DQS1	136	V _{SS}	46	CB3	166	V _{SS}	75	V _{DD}	195	ODT0	106	DQ51	226	V _{SS}
17	V _{SS}	137	DQ14	47	V _{SS}	167	NC	76	NC	196	A13	107	V _{SS}	227	DQ60
18	DQ10	138	DQ15	48	V _{TT}	168	$\overline{\text{RESET}}$	77	NC	197	V _{DD}	108	DQ56	228	DQ61
19	DQ11	139	V _{SS}	49	V _{TT}	169	NC	78	V _{DD}	198	NC	109	DQ57	229	V _{SS}
20	V _{SS}	140	DQ20	50	CKE0	170	V _{DD}	79	NC	199	V _{SS}	110	V _{SS}	230	DQS16
21	DQ16	141	DQ21	51	V _{DD}	171	A15	80	V _{SS}	200	DQ36	111	$\overline{\text{DQS7}}$	231	$\overline{\text{DQS16}}$
22	DQ17	142	V _{SS}	52	BA2	172	A14	81	DQ32	201	DQ37	112	DQS7	232	V _{SS}
23	V _{SS}	143	DQS11	53	$\overline{\text{ERR_OUT}}$	173	V _{DD}	82	DQ33	202	V _{SS}	113	V _{SS}	233	DQ62
24	$\overline{\text{DQS2}}$	144	$\overline{\text{DQS11}}$	54	V _{DD}	174	A12	83	V _{SS}	203	DQS13	114	DQ58	234	DQ63
25	DQS2	145	V _{SS}	55	A11	175	A9	84	$\overline{\text{DQS4}}$	204	DQS13	115	DQ59	235	VSS
26	V _{SS}	146	DQ22	56	A7	176	V _{DD}	85	DQS4	205	V _{SS}	116	V _{SS}	236	V _{DD} SPD
27	DQ18	147	DQ23	57	V _{DD}	177	A8	86	V _{SS}	206	DQ38	117	SA0	237	SA1
28	DQ19	148	V _{SS}	58	A5	178	A6	87	DQ34	207	DQ39	118	SCL	238	SDA
29	V _{SS}	149	DQ28	59	A4	179	V _{DD}	88	DQ35	208	V _{SS}	119	SA2	239	V _{SS}
30	DQ24	150	DQ29	60	V _{DD}	180	A3	89	V _{SS}	209	DQ44	120	V _{TT}	240	V _{TT}
								90	DQ40	210	DQ45				

6.0 DIMM Pin Description

Pin Name	Function	Pin Name	Function
A0 ~ A15	Address input (Multiplexed)	ODT0~ODT1	On Die Termination
A10/AP	Address Input/Auto pre-charge	CB0~CB7	ECC Data check bits Input/Output
BA0 ~ BA2	Bank Select	DQ0~DQ63	Data Input/Output
$\overline{CK0} \sim \overline{CK2}$, CK0~CK2	Clock input	$\overline{DQS0} \sim \overline{DQS8}$	Data strobes, negative line
CKE0, CKE1	Clock enable input	DM (0~8),	Data Masks/Data strobes (Read)
$\overline{S0}$, $\overline{S1}$	Chip select input	DQS0~DQS8	Data Strobes
\overline{RAS}	Row address strobe	RFU	Reserved for future used
\overline{CAS}	Column address strobe	V _{TT}	SDRAM I/O termination power supply
\overline{WE}	Write Enable	TEST	Memory bus test tool
SCL	SPD Clock Input	V _{DD}	Core Power
SDA	SPD Data Input/Output	V _{DDQ}	I/O Power
SA0~SA2	SPD Address	V _{SS}	Ground
Par_In	Parity bit for address & Control bus	V _{REFDQ}	SDRAM Input/Output Reference Supply
\overline{EVENT}	EVENT pin on TS/SPD part, Temperature event	V _{DDSPD}	Serial EEPROM Power Supply
Reset	Register and PLL control pin	V _{REFCA}	Command Address Reference Supply

7.0 Address Configuration

Organization	Row Address	Column Address	Bank Address	Auto Pre-charge
128Mx8(1Gb)base	A0-A13	A0-A9	BA0-BA2	A10

8.0 Functional Block Diagram: 1GB; 128x72 Module (Populated as 1 rank of x8 SDRAM Module)

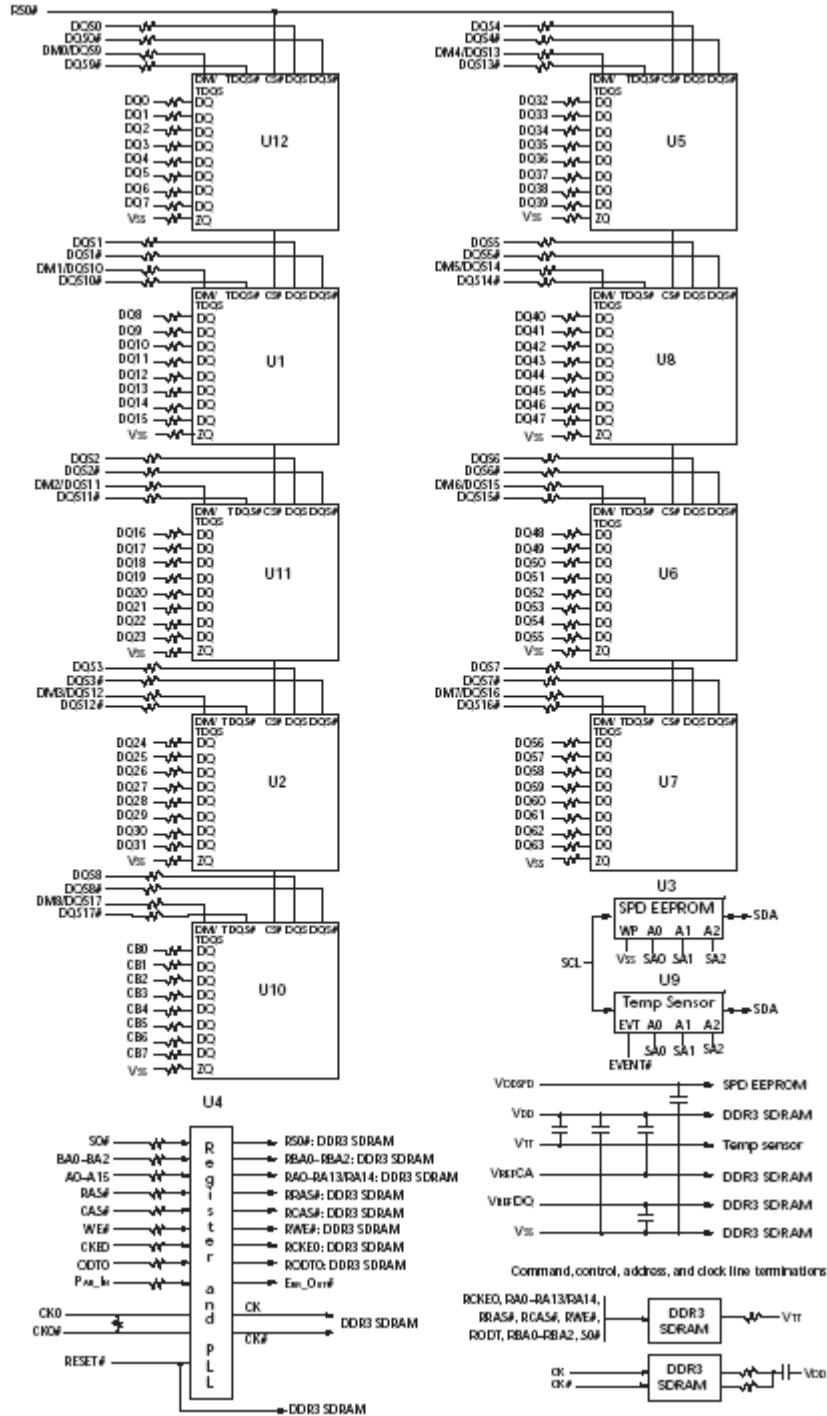

Note: 1. The ZQ ball on each DDR3 component is connected to an external $240\Omega \pm 1\%$ resistor that is tied to ground. It is used for the calibration of the component's ODT and output driver.

9.0 AC & DC Operating Conditions

Recommended operating conditions (Voltage referenced to V_{SS}=0V, TA=0 to 70°C)

Symbol	Parameter	Min	Typ	Max	Unit
V _{DD}	Supply Voltage	1.425	1.5	1.575	V
V _{DDQ}	Supply Voltage for Output	1.425	1.5	1.575	V
V _{REFDQ(DC)}	I/O Reference Voltage (DQ)	0.49*V _{DDQ}	0.50*V _{DDQ}	0.51*V _{DDQ}	V
V _{REFCA(DC)}	I/O Reference Voltage (CMD/Add)	0.49*V _{DDQ}	0.50*V _{DDQ}	0.51*V _{DDQ}	V
V _{TT}	Termination Voltage	0.49*V _{DDQ}	0.50*V _{DDQ}	0.51*V _{DDQ}	V

10.0 Capacitance (Max.)

Symbol	Parameter/Condition	Min	Max	Unit
CCK	Input capacitance, CK and \overline{CK}	-	11	pF
CI1	Input capacitance, CKE and \overline{CS}	-	12	pF
CI2	Input capacitance, Addr, RAS, CAS, WE	-	12	pF
CIO	Input capacitance, DQ, DM, DQS, \overline{DQS}	-	10	pF

11.1 AC Timing Parameters & Specifications

(AC operating conditions unless otherwise noted)

Parameter	Symbol	DDR3-1066		Units
		min	max	
Minimum Clock Cycle Time (DLL off mode)	tCK(DLL_OFF)	8	-	ns
Average Clock Period	tCK(avg)	-		ps
Clock Period	tCK(abs)	tCK(avg) min +tJIT(per)min	tCK(avg) max +tJIT(per)max	ps
Average high pulse width	tCH(avg)	0.47	0.53	tCK(avg)
Average low pulse width	tCL(avg)	0.47	0.53	tCK(avg)
Clock Period Jitter	tJIT(per)	-90	90	ps
Clock Period Jitter during DLL locking period	tJIT(per, lck)	-90	90	ps
Cycle to Cycle Period Jitter	tJIT(cc)	180	-	ps
Cycle to Cycle Period Jitter during DLL locking period	tJIT(cc, lck)	160	-	ps
Cumulative error across 2 cycles	tERR(2per)	- 132	132	ps
Cumulative error across 3 cycles	tERR(3per)	- 157	157	ps
Cumulative error across 4 cycles	tERR(4per)	- 175	175	ps
Cumulative error across 5 cycles	tERR(5per)	- 188	-188	ps
Cumulative error across 6 cycles	tERR(6per)	- 200	200	ps
Cumulative error across 7 cycles	tERR(7per)	- 209	209	ps
Cumulative error across 8 cycles	tERR(8per)	- 217	217	ps
Cumulative error across 9 cycles	tERR(9per)	- 224	224	ps
Cumulative error across 10 cycles	tERR(10per)	- 231	231	ps

11.2 AC Timing Parameters & Specifications(con't)

Parameter	Symbol	DDR3-1066		Units
		min	max	
Cumulative error across 11 cycles	tERR(11per)	- 237	237	ps
Cumulative error across 12 cycles	tERR(12per)	- 242	242	ps
Cumulative error across n = 13, 14 ... 49, 50 cycles	tERR(nper)	$tERR(nper)_{min} = (1 + 0.68\ln(n)) * tJIT(per)_{min}$ $tERR(nper)_{max} = (1 - 0.68\ln(n)) * tJIT(per)_{max}$		ps
Absolute clock HIGH pulse width	tCH(abs)	0.43	-	tCK(avg)
Absolute clock Low pulse width	tCL(abs)	0.43	-	tCK(avg)
Data Timing				
DQS, /DQS to DQ skew, per group, per access	tDQSQ	-	150	ps
DQ output hold time from DQS, /DQS	tQH	0.38	-	tCK(avg)
DQ low-impedance time from CK, /CK	tLZ(DQ)	-600	300	ps
DQ high-impedance time from CK, /CK	tHZ(DQ)	-	300	ps
Data setup time to DQS, /DQS referenced to Vih(ac)/Vil(ac) levels	tDS(base)	25	-	ps
Data hold time to DQS, /DQS referenced to Vih(ac)/Vil(ac) levels	tDH(base)	100	-	ps
DQ and DM Input pulse width for each input	tDIPW	490	-	ps
Data Strobe Timing				
DQS, /DQS READ Preamble	tRPRE	0.9	-	tCK
DQS, /DQS differential READ Postamble	tRPST	0.3	-	tCK
DQS, /DQS output high time	tQSH	0.38	-	tCK(avg)
DQS, /DQS output low time	tQSL	0.38	-	tCK(avg)
DQS, /DQS WRITE Preamble	tWPRE	0.9	-	tCK
DQS, /DQS WRITE Postamble	tWPST	0.3	-	tCK
DQS, /DQS rising edge output access time from rising CK, /CK	tDQSCK	-300	300	ps
DQS, /DQS low-impedance time (Referenced from RL-1)	tLZ(DQS)	-600	300	ps
DQS, /DQS high-impedance time (Referenced from RL+BL/2)	tHZ(DQS)	300	-	ps
DQS, DQS differential input low pulse width	tDQSL	0.45	0.55	tCK
DQS, DQS differential input high pulse width	tDQSH	0.45	0.55	tCK
DQS, DQS rising edge to CK, CK rising edge	tDQSS	-0.25	0.25	tCK(avg)
DQS, DQS falling edge setup time to CK, CK rising edge	tDSS	0.2	-	tCK(avg)
DQS, DQS falling edge hold time to CK, CK rising edge	tDSH	0.2	-	tCK(avg)
DLL locking time	tDLLK	512	-	nCK
internal READ Command to PRECHARGE Command delay	tRTP	max (4tCK, 7.5ns)	-	
Delay from start of internal write transaction to internal read command	tWTR	max (4tCK, 7.5ns)	-	
WRITE recovery time	tWR	15	-	ns
Mode Register Set command cycle time	tMRD	4	-	nCK
Mode Register Set command update delay	tMOD	max (12tCK, 15ns)	-	
CAS# to CAS# command delay	tCCD	4	-	nCK
Auto precharge write recovery + precharge time	tDAL(min)	WR + roundup (tRP / tCK(AVG))		nCK

11.3 AC Timing Parameters & Specifications(con't)

Parameter	Symbol	DDR3-1066		Units
		min	max	
Multi-Purpose Register Recovery Time	tMPRR	1	-	nCK
ACTIVE to PRECHARGE command period	tRAS	37.5	70,000	ns
ACTIVE to ACTIVE command period for 1KB page size	tRRD	max (4tCK,7.5ns)	-	
ACTIVE to ACTIVE command period for 2KB page size	tRRD	max (4tCK,10ns)	-	
Four activate window for 1KB page size	tFAW	37.5	-	ns
Four activate window for 2KB page size	tFAW	50	-	ns
Command and Address setup time to CK, CK referenced to Vih(ac) / Vil(ac) levels	tIS(base)	125	-	ps
Command and Address hold time from CK, CK referenced to Vih(ac) / Vil(ac) levels	tIH(base)	200	-	ps
Command and Address setup time to CK, CK referenced to Vih(ac) / Vil(ac) levels	tIS(base) AC150	-	-	ps
Control & Address Input pulse width for each input	tIPW	780	-	ps
Calibration Timing				
Power-up and RESET calibration time	tZQinitl	512	-	tCK
Normal operation Full calibration time	tZQoper	25	-	tCK
Normal operation short calibration time	tZQCS	64	-	tCK
Reset Timing				
Exit Reset from CKE HIGH to a valid command	tXPR	max(5tCK, tRFC+ 10ns)	-	
Self Refresh Timing				
Exit Self Refresh to commands not requiring a locked DLL	tXS	max(5tCK, tRFC+ 10ns)	-	
Exit Self Refresh to commands requiring a locked DLL	tXSDLL	tDLLK(min)	-	nCK
Minimum CKE low width for Self refresh entry to exit timing	tCKESR	tCKE(min) + 1tCK	-	
Valid Clock Requirement after Self Refresh Entry (SRE)	tCKSRE	max(5tCK, 10ns)	-	
Valid Clock Requirement before Self Refresh Exit (SRX)	tCKSRX	max(5tCK, 10ns)	-	
Power Down Timing				
Exit Power Down with DLL on to any valid command; Exit Precharge Power Down with DLL frozen to commands not requiring a locked DLL	tXP	max (3tCK,7.5ns)	-	
Exit Precharge Power Down with DLL frozen to commands requiring a locked DLL	tXPDLL	max(10tCK, 24ns)	-	
CKE minimum pulse width	tCKE	max(3tCK, 5.625ns)	-	
Command pass disable delay	tCPDED	1	-	nCK
Power Down Entry to Exit Timing	tPD	tCKE(min)	9*tREFI	tCK
Timing of ACT command to Power Down entry	tACTPDEN	1	-	nCK
Timing of PRE command to Power Down entry	tPRPDEN	1	-	nCK
Timing of RD/RDA command to Power Down entry	tRDPDEN	RL + 4 + 1	-	
Timing of WR command to Power Down entry (BL8OTF, BL8MRS, BL4OTF)	tWRPDEN	WL + 4 +(tWR/tCK)	-	nCK
Timing of WRA command to Power Down entry (BL8OTF, BL8MRS, BL4OTF)	tWRAPDEN	WL + 4 +WR+1	-	nCK
Timing of WR command to Power Down entry (BL4MRS)	tWRPDEN	WL + 2 +(tWR/ tCK(avg))	-	nCK

11.4 AC Timing Parameters & Specifications(con't)

Parameter	Symbol	DDR3-1066		Units
		min	max	
Timing of WRA command to Power Down entry(BL4MRS)	tWRAPDEN	WL +2 +WR +1	-	nCK
Timing of REF command to Power Down entry	tREFPDEN	1	-	
Timing of MRS command to Power Down entry	tMRSPDEN	tMOD(min)	-	
ODT Timing				
ODT high time without write command or with write command and BC4	ODTH4	4	-	nCK
ODT high time with Write command and BL8	ODTH8	6	-	nCK
Asynchronous RTT turn-on delay (Power-Down with DLL frozen)	tAONPD	1	9	ns
Asynchronous RTT turn-off delay (Power-Down with DLL frozen)	tAOFPD	1	9	ns
ODT turn-on	tAON	-300	300	ps
RTT_NOM and RTT_WR turn-off time from ODTL off reference	tAOF	0.3	0.7	tCK(avg)
RTT dynamic change skew	tADC	0.3	0.7	tCK(avg)
Write Leveling Timing				
First DQS pulse rising edge after tDQSS margining mode is programmed	tWLMRD	40	-	tCK
DQS/DQS delay after tDQS margining mode is programmed	tWLDQSEN	25	-	tCK
Setup time for tDQSS latch	tWLS	245	-	ps
Hold time of tDQSS latch	tWLH	245	-	ps
Write leveling output delay	tWLO	0	9	ns
Write leveling output error	tWLOE	0	2	ns

**12.0 Physical Dimensions: (128Mx8 Based)
128Mx72 (1 Rank)**

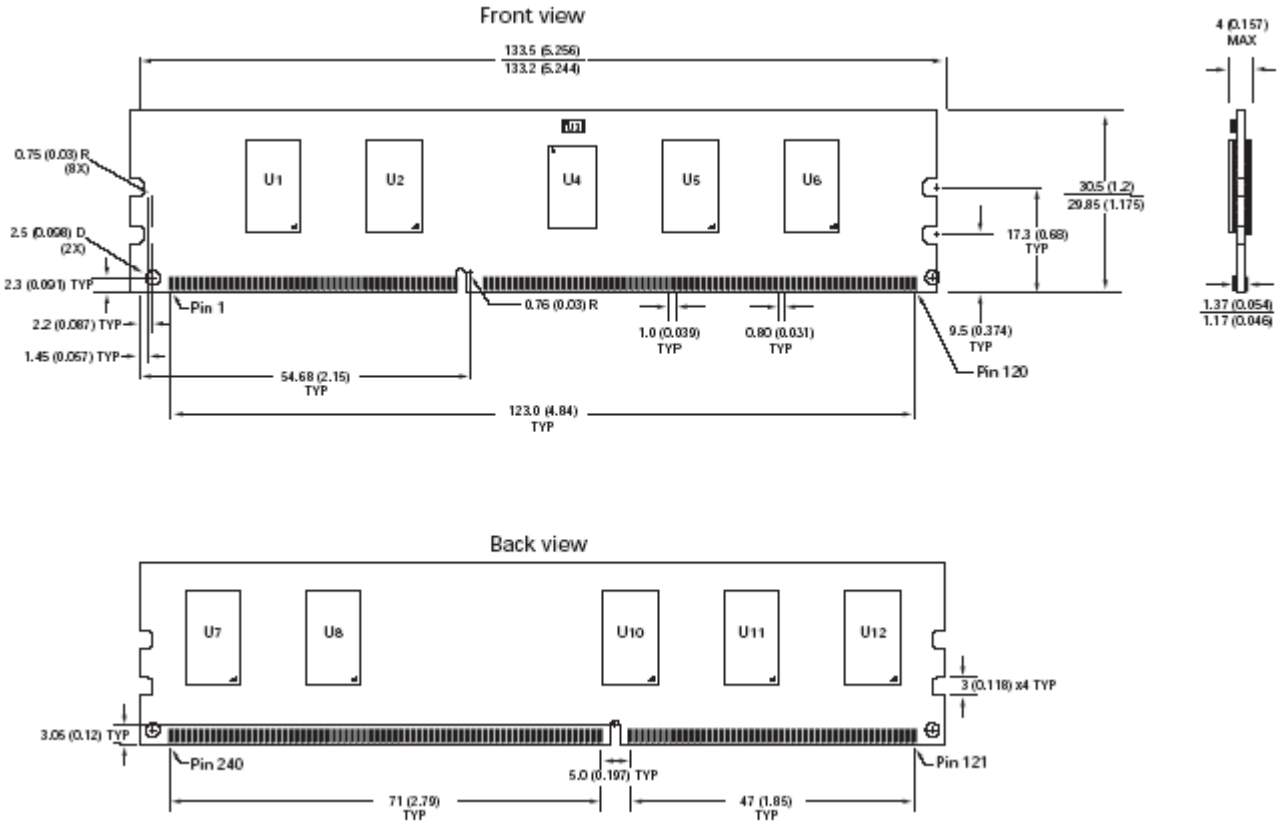

Tolerances: $\pm 0.005(.13)$ unless otherwise specified